

Model Sizing Form for INDXIA Indexing Drive

SSH AUTOMATION PTE LTD

Customer's Company, Department			
Address			
Name			
TEL		FAX	
E-mail			

● Number of stops S
 ● Dwell time t_1 sec
 ● Index time t_2 sec

Index Dial Application

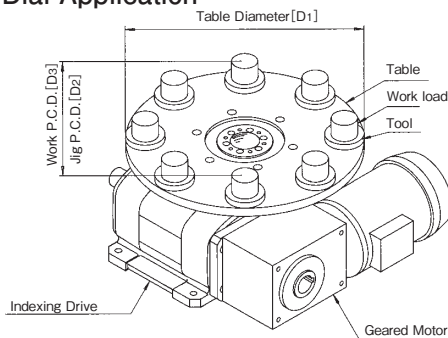

● Table diameter D_1 mm
 ● Table weight W_1 kg
 ● Jig P.C.D. D_2 mm
 ● Weight per tool W_2 kg
 ● Number of tool n_2
 ● Work P.C.D. D_3 mm
 ● Weight per work W_3 kg
 ● Number of work n_3

● Feed pitch P mm
 ● Weight of chain with attachment W_1 kg
 ● Weight of tool W_2 kg
 ● Weight of work W_3 kg
 ● Sprocket diameter D mm
 ● Weight per sprocket W_4 kg
 ● Number of sprocket n_4
 ● Coefficient of friction μ

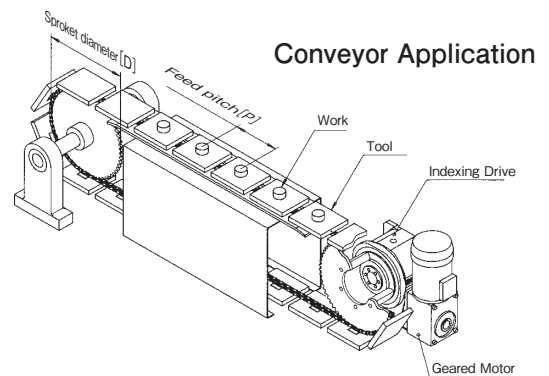

Geared Motor	Yes · No	Inverter	Yes · No
Torque Limiter	Yes · No	Timing Cam-Photo Switch	Yes (set) · No

Memo

Please complete form and email to sshauto@singnet.com.sg
 URL: www.sshautomation.com.sg